

**Nineteenth Meeting of the Council of the
Town of Maple Creek Held on November 28, 2017**

- 1. PRESENT:**
- 2. ABSENT:**
- 3. CALL TO ORDER: 7:30 p.m.**
- 4. AGENDA:**
- 5. MINUTES:**
 - a. Regular Meeting November 14, 2017
- 6. NOTICE OF PROCLAMATIONS:**
- 7. PRESENTATIONS AND RECOGNITIONS:**
- 8. PUBLIC HEARINGS:**
- 9. DELEGATIONS:**
- 10. COMMUNICATIONS:**
 - a. Government of Saskatchewan
- 11. PAYMENT OF ACCOUNTS:**
 - a. Accounts Payable
- 12. REPORTS OF ADMINISTRATION & COMMITTEES:**
 - a. CAO Report
- 13. UNFINISHED BUSINESS:**
- 14. NEW BUSINESS:**
 - a. Cowtown Christmas – street closure
 - b. Ray Broderick – Discharge of firearms within Town limits
 - c. Creekside Estates – 15 minutes parking zone in front of 319 Jasper Street
 - d. Creekside Estates Annual Report
 - e. Xplornet WIFI antenna on Pacific Ave.
- 15. MAYOR AND COUNCILLORS FORUM:**
- 16. ADJOURNMENT:**

MINUTES OF THE NINETEENTH REGULAR MEETING OF THE COUNCIL OF THE TOWN OF MAPLE CREEK HELD ON NOVEMBER 14, 2017

PRESENT Mayor Barry Rudd, Councillors Cara Teichroeb, Elaine Hawrylak, Michelle McKenzie, CAO Don McLeod. Barry Elderkin phoning in.

ABSENT: Michael Morrow and Kevin Rittinger

CALL TO ORDER

Mayor Barry Rudd called the meeting to order at 7:30 PM.

AGENDA

17-MC-367 Elderkin/Teichroeb – That, the Agenda of the Nineteenth Regular Meeting of the Council of the Town of Maple Creek held on November 14, 2017 be accepted as adopted. Carried

MINUTES OF THE REGULAR MEETING – OCTOBER 10, 2017

17-MC-368 Hawrylak/Teichroeb – That, the minutes of the Eighteenth Regular meeting of the Council of the Town of Maple Creek held on October 30, 2017 be adopted as circulated. Carried

17-MC-369 Teichroeb/Hawrylak – That, the minutes of the Special Meeting of the Council of the Town of Maple Creek held on November 6, 2017 be adopted as circulated. Carried

17-MC-370 Teichroeb/McKenzie – That, the minutes of the Special Meeting of the Council of the Town of Maple Creek held on November 10, 2017 be adopted as circulated. Carried

NOTICE OF PROCLAMATIONS

17-MC-371 McKenzie/Teichroeb – That, the Proclamation of Metis Week – this week November 13th – 17th of 2017.

DELEGATIONS

a. Blaine Filthaut – Chamber of Commerce – 7:45 pm.

Carried

COMMUNICATIONS

17-MC-372 Teichroeb/McKenzie – That, the correspondence as listed and circulated now be filed. Carried

PAYMENT OF ACCOUNTS

17-MC-373 Hawrylak/McKenzie – That, Council approve the Payroll vouchers 3090 to 3150 in the amount of \$72,215.73 as attached as Schedule B to these minutes. Carried

17-MC-374 Hawrylak/McKenzie – That, Council approve the accounts totaling \$69,314.04, cheques #6754-#6779 as listed on Schedule "A" and accounts totaling \$8989.93, cheques #6780-#6787 as listed on Schedule "C" and accounts totaling \$14,752.69, cheques #6788 - #6791 as listed on Schedule "D" and accounts totaling \$96,963.21, cheques #6792 - #6839 as listed on Schedule "E" and accounts totaling \$3097.20, cheques #6840 - #6841 as listed on Schedule "F" and forming part of these minutes. Carried

MINUTES OF THE NINETEENTH REGULAR MEETING OF THE COUNCIL OF THE TOWN OF MAPLE CREEK HELD ON NOVEMBER 14, 2017

17-MC-375 Teichroeb/McKenzie – That, Council approve the Bank Reconciliation for September as presented.

Carried

17-MC-376 Elderkin/Hawrylak – That, Council approve the monthly financial statement for October 2017 as presented.

Carried

REPORTS OF ADMINISTRATION & COMMITTEES

17-MC-377 Elderkin/Teichroeb – That, Council hereby accept the Administrative Reports from the CAO, Parks and Rec Manager, and Manager of Economic Development Report for the month of October 2017 as circulated and that the reports be filed.

Carried

UNFINISHED BUSINESS

NEW BUSINESS

TOWN OF LUMSDEN

17-MC-378 Elderkin/Teichroeb – That, Council support the resolution as put forward by the Town of Lumsden in regards to RCMP policing costs.

Carried

MINOR SPORTS

17-MC-379 Teichroeb/Hawrylak – That, Council accept for information purposes the request from Maple Creek Minor Sports, Slo-Pitch and Senior Ball for dugout repairs.

Carried

MOTION 17-MC-193 AMENDMENT

17-MC-380 Hawrylak/Teichroeb – That, Council amend motion 17-MC-193 to read the Willowbend Motel from the Cypress Hills Motor Inn but all other parts of the motion remain unchanged.

Carried

JOINT FIRE COMMITTEE

17-MC-381 Teichroeb/McKenzie – That, Council appoint Barry Elderkin, Michael Morrow and the CAO to sit as the Joint Fire Committee with the R.M. of Maple Creek No. 111.

Carried

ARENA CHRISTMAS HOLIDAY HOURS

17-MC-382 Teichroeb/Hawrylak – That, Council authorize the Maple Creek Arena to be closed after the public skate on December 24 until Noon (12:00 PM) December 27, 2017 for statutory holidays. Also, there will be public skating and shinny daily until the regular schedule resumes on January 2, 2018.

Carried

MEMORIAL PLAQUES

17-MC-383 Elderkin/McKenzie – That, memorial plaques on the end of the Columbarium be priced at \$500.00 each.

Carried

MINUTES OF THE NINETEENTH REGULAR MEETING OF THE COUNCIL OF THE TOWN OF MAPLE CREEK HELD ON NOVEMBER 14, 2017

RESCIND MOTION MC-17-361

- 17-MC-384 Elderkin/Mckenzie – That, Council rescind the following motion:
MC-17-361 – That, we put a tender in the newspaper for the renovation contract to be received by November 13, 2017, to be opened at the November 14, 2017 Council Meeting. Carried

THREE MONTH LEAVE OF ABSENCE

- 17-MC-385 Hawrylak/Teichroeb – That, Council accept the request from Councillor Rittinger for a three month leave of absence from his duties of Council due to medical reasons. Carried

314 LONSDALE

- 17-MC-386 McKenzie/Teichroeb – That, Council approve the demolition request of Carolyn Beckman for the current house located at 314 Lonsdale Street. Further, that Council approve the request of Carolyn Beckman to move the house from 503 Marsh Street to 314 Lonsdale Street providing all current building codes are applied and adhered to. Carried

BINKLEY FUNERAL HOME

- 17-MC-387 Elderkin/Hawrylak – That, Council advise Binkley Funeral Services (MC) Ltd. that Council will demolish the shed currently used and if they wish to erect a building near the town building it would be at their cost. Carried

ADJOURNMENT

- 17-MC-388 McKenzie – That, Council adjourn at 9:58 PM. Carried

Mayor

CAO



October 31, 2017

Town of Maple Creek
Box 428
MAPLE CREEK SK S0N 1N0



Dear Sir/Madam:

I am writing to you about the results of the Ministry of Justice, Courts and Tribunals Division's, review of fine revenue distribution within the new database system, Criminal Justice Information Management System (CJIMS).

Since my letter on November 15, 2016, we commenced utilizing CJIMS on January 30, 2017. As is good practice with system changes of this magnitude, we recently undertook a review of all commissions and fine revenue distribution. This review has identified two areas that require our follow up:

- 1) New account referrals to collection agencies - All new account referrals to collection agencies, since the inception of CJIMS until July 31, 2017, did not distribute holdback commission amounts to collection agencies correctly. While no money was lost, when revenue was received during this time period, the collection agency commissions were paid to municipalities rather than to the appropriate collection agency.

As a result, it was determined that your town will not have an adjustment to revenue.

- 2) Fine revenue - Some municipalities entitled to fine revenue were setup incorrectly in CJIMS. We are in the process of identifying which organizations have been affected by an underpayment, and calculating the amount of the underpayment. We will confirm with you in writing the impact of this review on your town in the coming weeks.

The Ministry of Justice remains committed to regular reviews to ensure accurate disbursement of revenue and commissions. If you have any questions, please do not hesitate to contact Curtis Kosolofski, Director, Financial and Corporate Services, at (306) 787-5972.

Yours truly,

Jan Turner
Assistant Deputy Minister
Courts and Tribunals Division



CAO'S REPORT – November 14, 2017

1. I have been working on the presentation for the Town Forum on December 5, 2017.
2. Attended 23rd Annual Law Review in Saskatoon with Mayor Rudd and Councillor McKenzie in Saskatoon on November 22 & 23. The sessions were excellent and provides me with much needed knowledge.
3. Took Friday November 24 as an EDO to attend UMAAS meeting in Regina on the 24 & 25.
4. Initial survey for the new landfill cell has been completed. AE has made application to Sask Environment to extend permit to September 2018.



November 1, 2017

Town of Maple Creek

Cowtown Christmas

Cowtown Christmas time is quickly approaching and in this respect please find below some of the details that require coordination:

- Date set for December 7th
- Will require the first two blocks of Jasper to be closed to traffic, (barricades), at 5:00 pm
- Firepots to be placed on the two blocks
- Santa will arrive via carriage or sleigh at 6:45
- Hay rides will take place from 6:00 to 7:00 at the corner of 1st & Jasper and then from 7:00 until 8:00 at the corner of 2nd & Jasper

In addition to the above, there is currently discussion on expanding on Cowtown Christmas with additional scheduled activities. Once all details are known, we will advise in order that the details can be included with town promotions.

For the most part the format of Cowtown Christmas is in line with previous years and we thank everyone in advance to make this a successful and joyful event.

Yours truly

A handwritten signature in black ink, appearing to read 'Blaine Filthaut', with a long, sweeping underline.

Blaine Filthaut
President

Maple Creek Chamber of Commerce

Creekside Estates Inc.
Box 638
Maple Creek, SK
S0N 1N0
November 21, 2017

To the Mayor and Council of the Town of Maple Creek

Creekside Estates Inc. is requesting that the Council of the Town of Maple Creek consider establishing a 15 minute parking zone in front of the Creekside Estates premises, at 319 Jasper Street.

We understand that the process involves a provincial decision, and that it can take some time.

We ask your consideration of this request.

Yours truly,



Anne Weisgerber
Secretary/Treasurer

Creekside Estates Inc.
Box 638
Maple Creek, SK
S0N 1N0
November 21, 2017

To the Mayor and Council of the Town of Maple Creek

As per the constitution of Creekside Estates Inc, and the agreement between the Town of Maple Creek and Creekside Estates Inc, please find enclosed the following:

1. Copy of the reviewed financial statement for the fiscal period ending June 30, 2017.
2. Operating budget for the period ending June 30, 2018.
3. Minutes of the Annual Meeting held October 30, 2017.

At the Annual Meeting held October 30, 2017, the following Board members were elected:

Sam Boychuk
Doug Noble
Rodger Fettes
Harvey Pickett
Anne Currah
Doug Haroldson
Anne Weisgerber
Shirley Sharp
Calvin Siegle
Ellaine Hawrylak

Please appoint these as the Board of Directors for Creekside Estates for the 2017/18 year.

Please feel free to contact the Board of Directors if you have any questions.

Yours truly,



Anne Weisgerber
Secretary/Treasurer

Enc: 3

Creekside Estates Inc.
Annual Meeting
10:00am, October 30, 2017
Creekside Estates Common Room
Maple Creek, SK

1. Attendance – the following were in attendance:

a. As Board Members:

- i. Sam Boychuk
- ii. Doug Noble
- iii. Ellaine Hawrylak
- iv. Rodger Fettes
- v. Harvey Pickett
- vi. Anne Currah
- vii. Doug Haroldson
- viii. Anne Weisgerber

b. As Interested Tenants:

- i. Bob Eccleston
- ii. Lorraine Good
- iii. Wallace Good
- iv. Ev Southwood
- v. Milta Tribble
- vi. Harry Opsal
- vii. Irene Opsal
- viii. June Filthaut
- ix. Coralie Wiebe
- x. Lorraine Lindstrom
- xi. Edith Reamer
- xii. Shirley Melchoir
- xiii. Herb Duncan

2. Call to Order – Meeting was called to order by President Sam Boychuk at 10:00am.

3. Approval of Agenda

#2017-AM01 PICKETT/NOBLE
That the agenda as circulated be approved.
Carried

4. Minutes of the 2016 Annual General Meeting

#2017-AM02 HAWRYLAK/NOBLE
That the minutes of the 2016 Annual Meeting be adopted as circulated.
Carried

5. Audited Financial Statement

#2017-AM03 NOBLE/HAROLDSON
That the Audited Financial Statement as of June 30, 2017, be approved
as circulated.
Carried

Scrutineer Migowsky announced that the following list of names were declared elected:

Doug Noble
Sam Boychuk
Rodger Fettes
Anne Weisgerber
Anne Currah
Doug Haroldson
Harvey Pickett
Shirley Sharp
Calvin Siegle

#2017-AM10 PICKETT/NOBLE
That the ballots be destroyed.
CARRIED

The above list of Directors was welcomed to the Board.

11. Adjournment

#2017-AM11 HAWRYLAK/FETTES
That the meeting be adjourned.
CARRIED

The meeting was adjourned at 10:35am.

Approved by:

Sam Boychuk, President

Date

Discussion of tenant concerns followed the meeting.

As required by the Town of Maple Creek Fire Inspector, a Fire Drill for tenants followed the annual meeting.



HIGH PERFORMANCE ANTENNAS

DIAMETER: 0.6 m

ELECTRICAL SPECIFICATIONS

	A-ANT-11G-2-C	A-ANT-13G-2-C	A-ANT-15G-2-C	A-ANT-18G-2-C	A-ANT-23G-2-C	A-ANT-26G-2-C	A-ANT-28G-2-C	A-ANT-38G-2-C
Frequency Band, GHz	10.7-11.7	12.7-13.25	14.25-15.35	17.7-19.7	21.2-23.6	24.25-26.25	27.3-31.3	37.0-40.0
Bottom Band Gain, dBi	34.2	35.6	36.8	38.2	39.7	40.7	41.8	44.0
Mid Band Gain, dBi	34.5	35.8	37.0	38.6	40.2	41.1	42.2	44.3
Top Band Gain, dBi	34.8	36.0	37.3	39.0	40.7	41.5	42.7	44.7
Beamwidth, degrees	3.4	2.8	2.4	2.1	1.7	1.5	1.3	1.0
Front/Back, dB	55.0	62.0	64.0	67.0	66.0	68.0	68.0	66.0
XPD, dB	30.0	30.0	30.0	30.0	30.0	30.0	30.0	30.0
Return Loss, dB	16.1	16.1	16.1	16.1	16.1	16.1	16.1	16.1
Pattern								
ETSI EN201217 Class	RIC2	RIC3	R2C3	R2C3	R3C3	R4C3	R4C3	R5C3
FCC Part 101	-	-	-	Cat A	Cat A	Cat A	-	Cat A
Antenna Pattern	RPE-74-000119-02-01	RPE-74-000120-02-01	RPE-74-000121-02-01	RPE-74-000066-02-01	RPE-74-000067-02-01	RPE-74-000068-02-01	RPE-74-000125-02-01	RPE-74-000126-02-01

OUTLINE DIMENSIONS

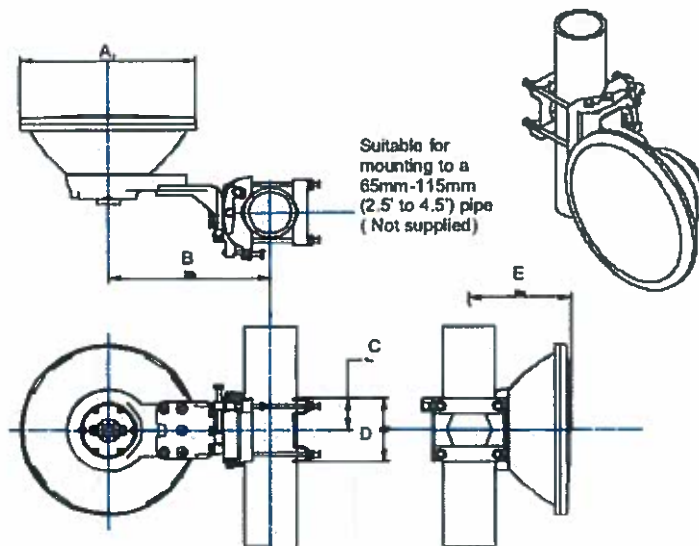

Antenna Dimensions, mm (in)

A	663 (26.10)
B	358 (14.10)
C	72 (2.80)
D	143 (5.60)
E	335 (13.20)

Antenna Fine Adjustment

Fine Azimuth	± 10°
Fine Elevation	± 25°

Actual antenna appearances may differ from shown.

HIGH PERFORMANCE ANTENNAS –DIAMETER: 0.6 M

WIND FORCES

The axial, side and twisting moment forces provided are maximum loads applied to the tower by the antenna at a wind survival speed of 200 km/h (125 mph). In every instance they are the result from the most critical direction for each parameter. The individual maximums may not occur simultaneously. All forces are referenced to the antenna mounting pipe.

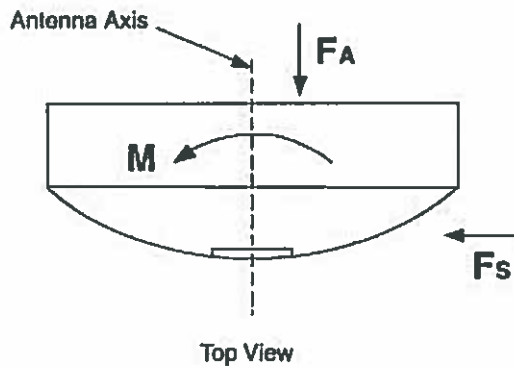

Axial Force	F_A max	682 N
Side Force	F_s max	317 N
Moment	M_T max	244 N

Antenna Weights Including Mount

Net Weight, kg 12.3

Antenna Packed Weights (Gross)

Gross Weight, kg 21.7

Antenna Dimensions (Single Unit Pack)

Dimensions, cm (in) 71 x 71 x 61 (29 x 29 x 27)



Connect with us today!

600-411 Legget Drive
Ottawa, Ontario, Canada, K2K 3C9
Tel: 613-599-9991
Fax: 613-599-4225

nasales@dragonwaveinc.com
emeasales@dragonwaveinc.com

www.dragonwaveinc.com

Information subject to change without notice. DragonWave™ and AirPair™ are registered trademarks of DragonWave Inc.

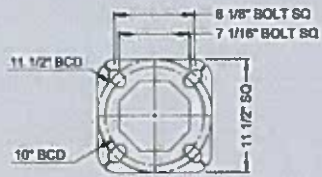

TYPE A

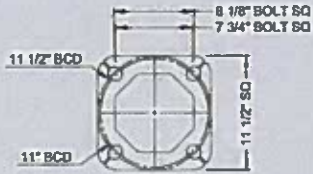

TYPE B



TYPE C

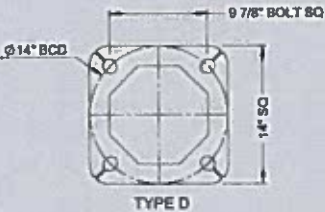

TYPE D



SPECIFICATIONS

Product Number	Description	Height (ft)	Weight (lb)	Base Plate Type	Maximum EPA (sq.ft.)			
					80 mph	90 mph	100 mph	110 mph
101-70-1NST12-Fx	NST 12, Straight Tapered	12'	109	A	61.5	48.5	39.0	32.0
101-70-1NST15-Fx	NST 15, Straight Tapered	15'	130	A	48.5	38.5	31.0	25.0
101-70-1NST18-Fx	NST 18, Straight Tapered	18'	151	A	38.5	30.5	24.0	19.5
101-70-1NST20-Fx	NST 20, Straight Tapered	20'	165	A	33.5	26.0	20.5	16.5
101-70-1NST25-Fx	NST 25, Straight Tapered	25'	200	A	24.0	18.5	14.0	11.0
101-70-1NST30-Fx	NST 30, Straight Tapered	30'	255	B	23.5	17.5	13.5	10.0
101-70-1NST35-Fx	NST 35, Straight Tapered	35'	292	B	17.5	12.5	9.0	6.5
101-70-1NST40-Fx	NST 40, Straight Tapered	40'	365	C	18.0	13.0	9.0	6.0
101-70-1NST4H-Fx	NST 40, HD, Straight Tapered	40'	440	D	27.0	20.0	15.0	11.0

Finishing Code: x=1 for Galvanized; x=3 for Powder Coated; x=5 for Galvanized & Powder Coated.

Standard Tenon Size: 2 3/8" Outside Diameter x 5" Long.

Poles can be furnished with tenons with outside diameters of 2 7/8", 3 1/2".

Wind speeds (mph) in the table denote the maximum wind gust speed at the project site (i.e. gust factor included).

Anchor Bolt Diameter: 1" diameter.

Maximum EPA rating includes fixture(s) and supporting arm(s) and is for standard pole installation on concrete bases/footings.

Pole designs based on AASHTO Standard Specifications for Structural Supports for Highway Signs, Luminaires, and Traffic Signals.

Contact Sales Team for custom sizes and/or custom applications.